

PLEASE READ this guide prior to installation to familiarise yourself with the various stages of construction required. Carefully open the pack and check the contents against the parts and fittings check list. Do not destroy any of the packaging until you are certain that you have all the necessary parts. Please ensure that the packaging is disposed of in a safe and environmentally friendly way. In the unlikely event of missing or damaged parts, please email customer services: hello@time4sleep.co.uk Please have this guide close at hand, quoting the part code reference numbers shown, when requesting spare or replacement parts.

Warnings

- This product should only be used on a firm and level floor.
- Make sure the legs/base always remains in contact with the floor.
- Keep small parts out of the reach of children during assembly to prevent choking.
- DO NOT use power tools to construct this product.
- DO NOT tighten screws until parts are assembled or as advised in this guide.
- DO NOT over tighten screws or bolts.
- DO NOT use this product if parts are missing, damaged or worn.
- DO NOT sit, or stand on the product.

Care Information

- To clean, wipe with a damp cloth.
- Never use scourers, abrasives or chemical cleaners.
- Do not use solvent based cleaners or detergents as they can bleach or damage the product.

Parts Identification

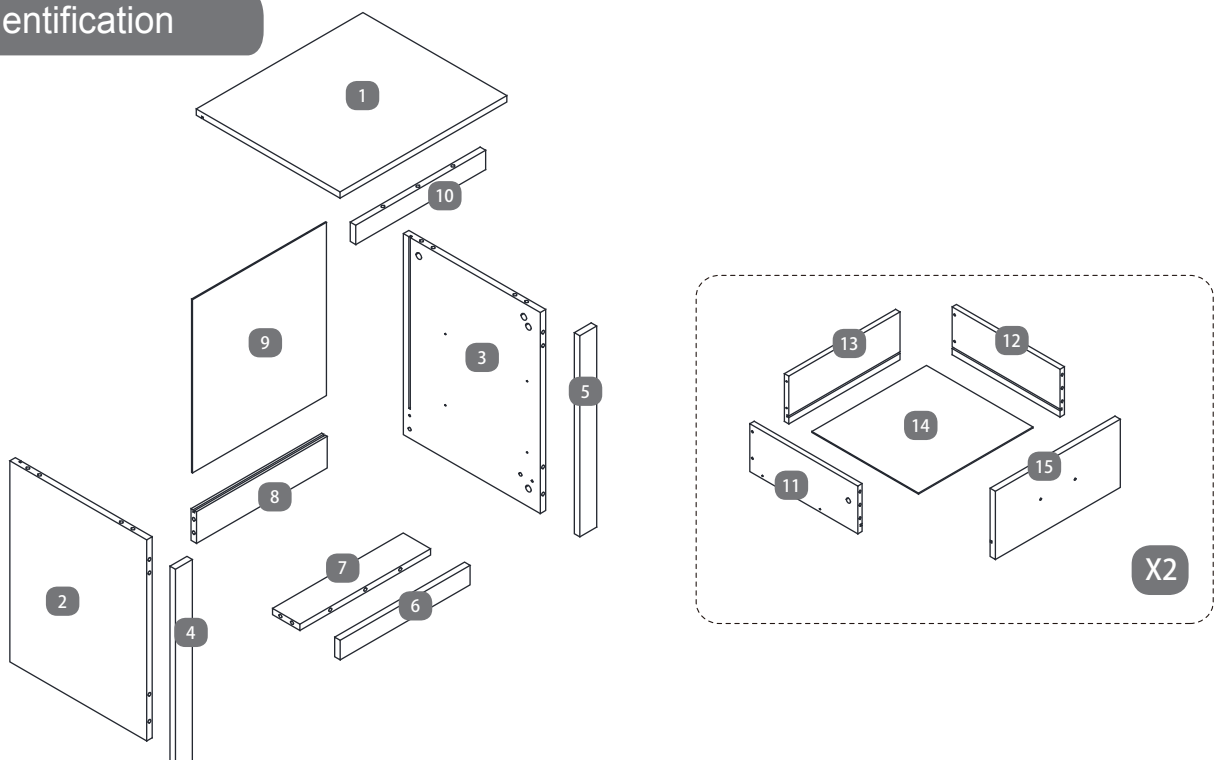

Parts Checklist

PACK	1/1	Qty	Qty
1	Top Panel	1	9
2	Left Side Panel	1	10
3	Right Side Panel	1	11
4	Left Decor Panel	1	12
5	Right Decor Panel	1	13
6	Plinth	1	14
7	Bottom Rail	1	15
8	Back Rail	1	

Fittings Checklist

HARDWARE NEEDED FOR CABINET ASSEMBLY

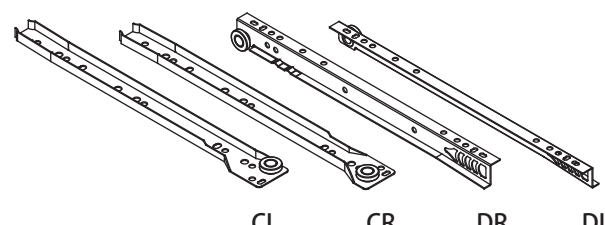
Code	Description	Qty	Code	Description	Qty
a	Metal Cam Dowel (Ø7 x 40mm)	x16	m	Handle	x2
b	Cam Lock (Ø 15 x 12mm)	x16	n	Screw (Ø 4 x 25mm)	x4
c	Thin Thread Metal Cam Dowel (Ø5 x 34mm)	x4	Drawer slide Set		x2
d	Cam Lock (Ø12 x 10mm)	x4			
e	Wooden Dowel (Ø 8 x 30mm)	x14			
f	Wooden Dowel (Ø 6 x 30mm)	x8			
g	Screw (Ø 4 x 35 mm)	x8			
h	Screw (Ø 3.5 x 12 mm)	x28			
j	Screw (Ø 3 x 16 mm)	x6			
k	Back Panel Support Fitting	x6			
l	Foot Pad (Ø 12 x 5 mm)	x4			

Additional Tools Required

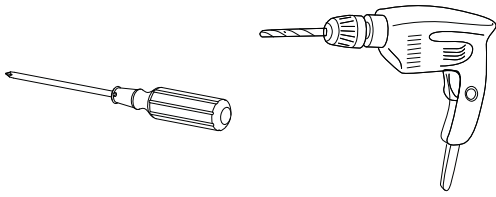

General Hints & Tips



Please retain your assembly instruction and tools provided for future use. Periodically check that all bolts are still tight.



Assembly requires two persons.



Approximate time to assemble this product

Care & Maintenance

In the unlikely event of missing or damaged parts, please contact your retailer. Please have this guide at hand quoting the part code reference numbers shown when requesting spare or replacement parts.

General Information

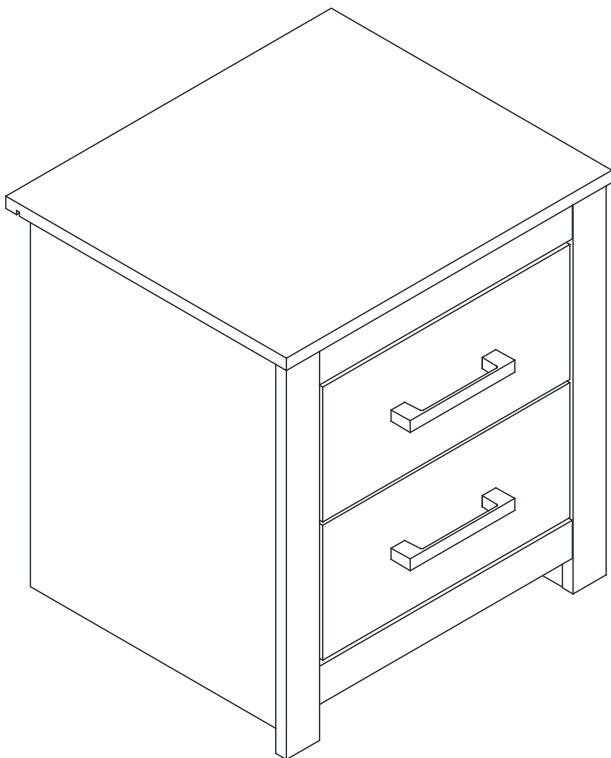

- This product is designed to hold 20Kg in total spread evenly over the whole unit.
- Do not exceed this weight.
- We recommend that this unit is assembled in the room intended for use.
- When you are ready to start, make sure that you have the right tools, plenty of space and a clean, dry area for assembly.
- Unwrap all packaging materials and place the components on top of the carton box or on a clean floor to prevent them from scratching.
- Check the pack and make sure you have all the parts listed.
- Ensure that this product is fully assembled as illustrated before use.
- Check all screws or bolts are tightened and inspect regularly.
- Tools are not included unless they are specified in the parts list.

Cabinet Assembly

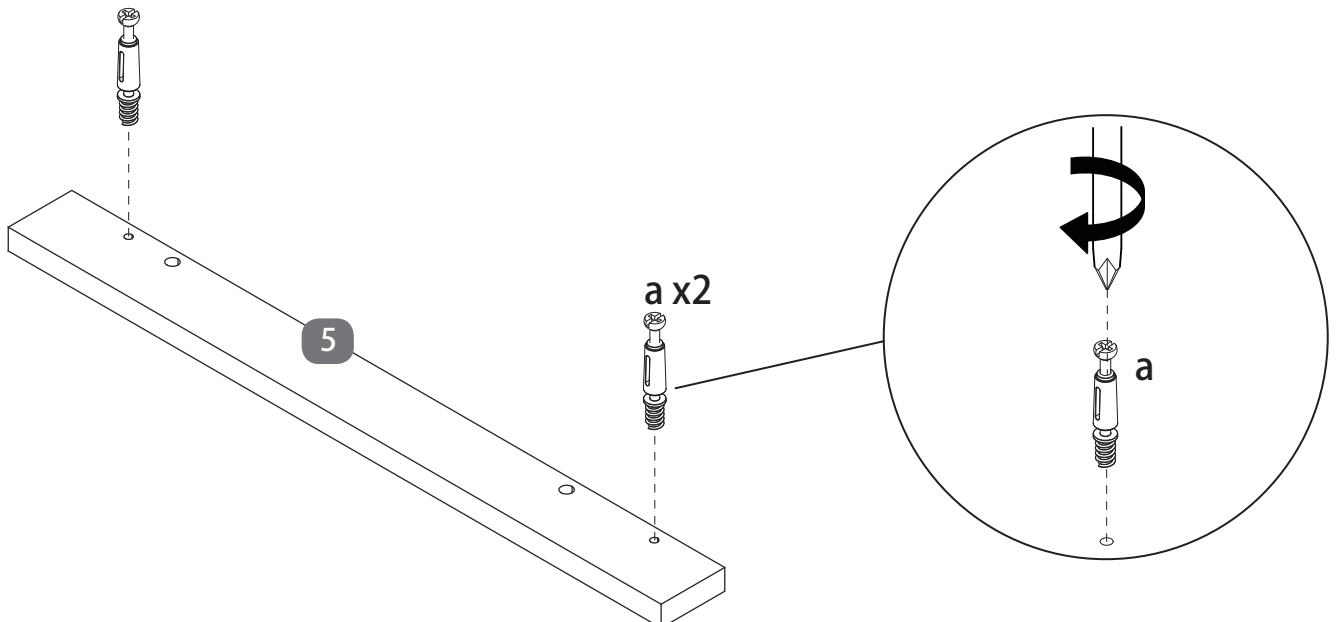
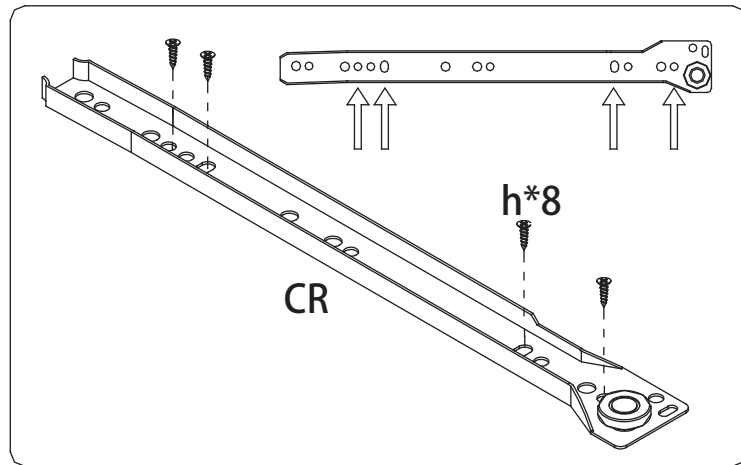
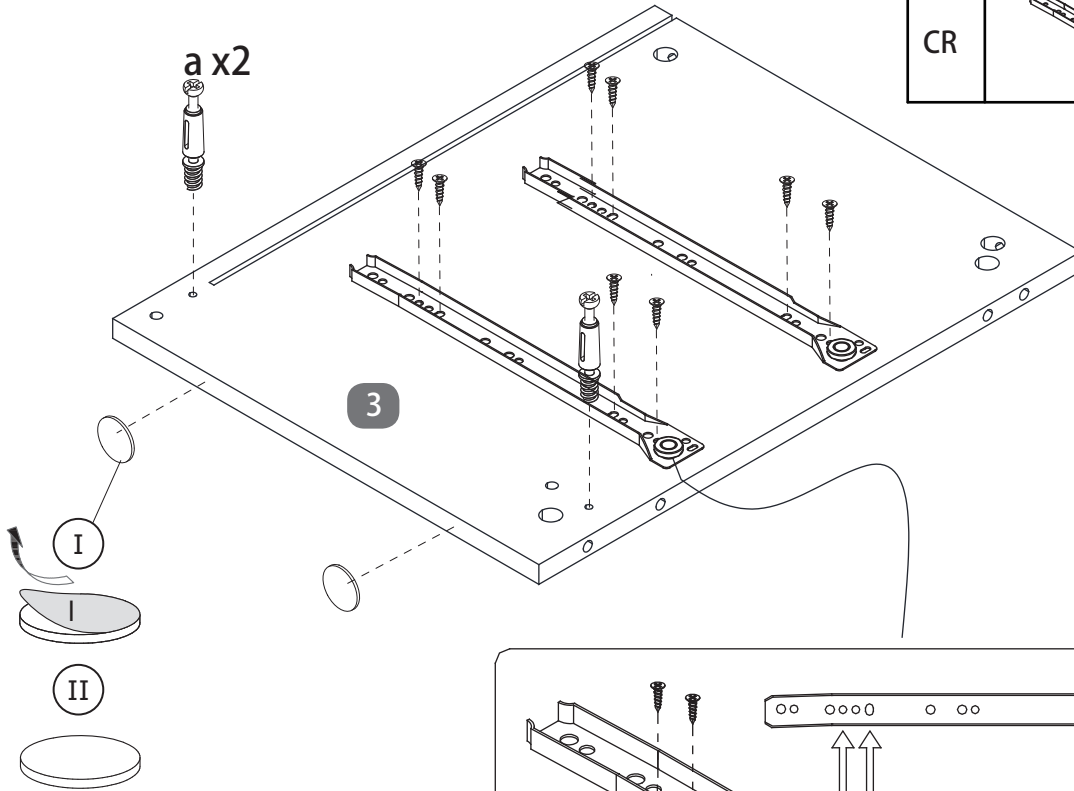

Stage
1

a		4	
h		8	
l		2	
CR		2	



Cabinet Assembly

Stage
2

b		2	
e		2	

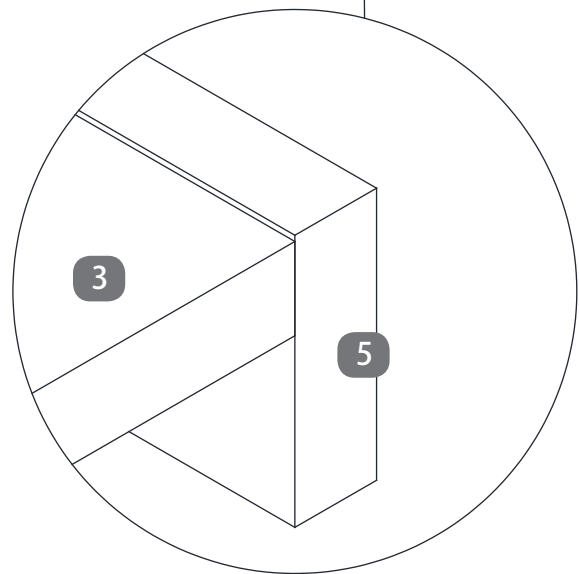
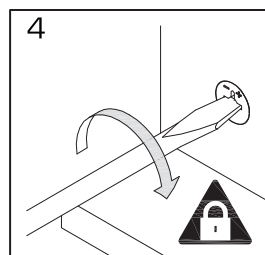
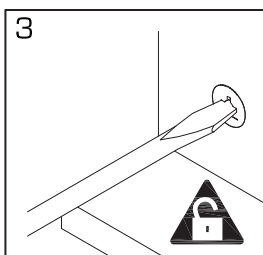
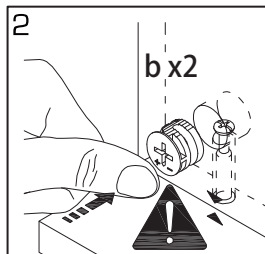
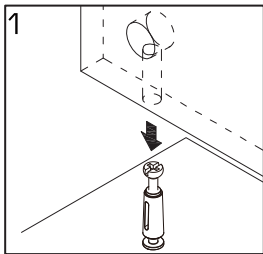
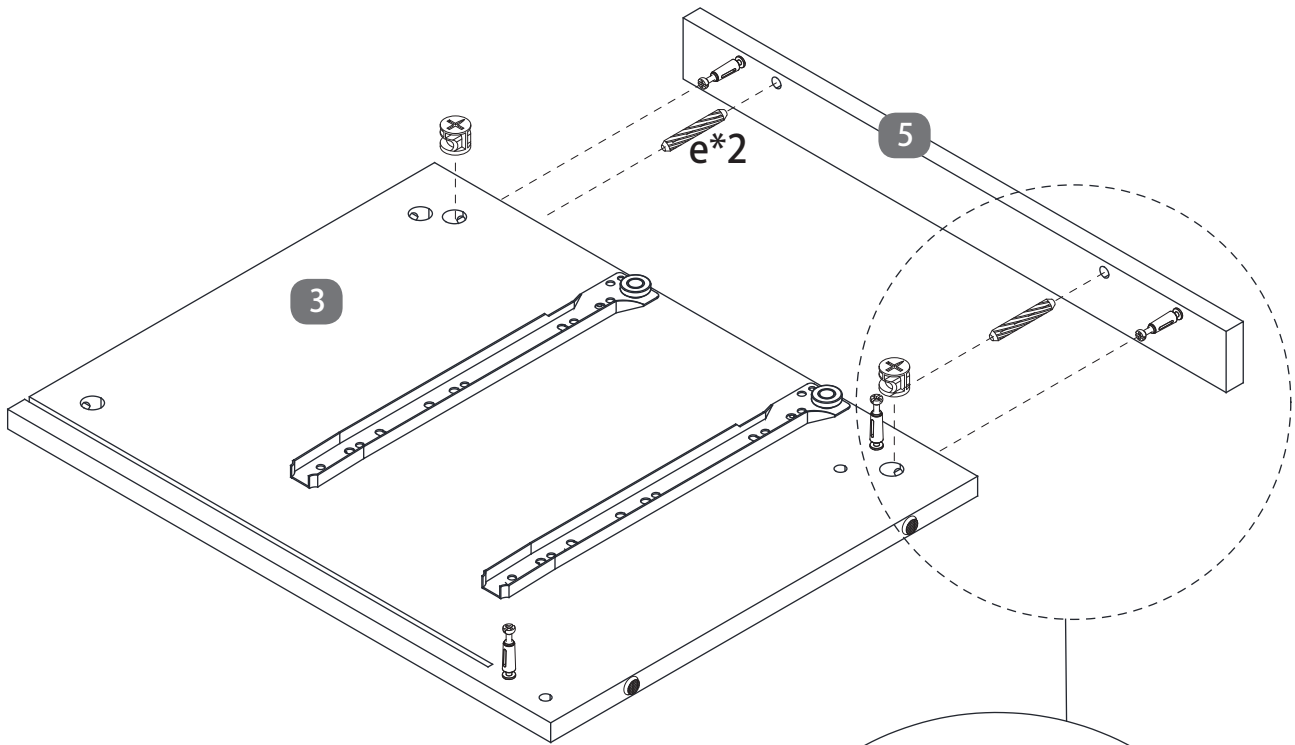

Cabinet Assembly

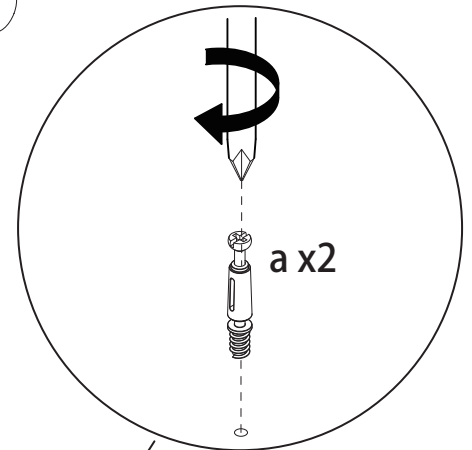
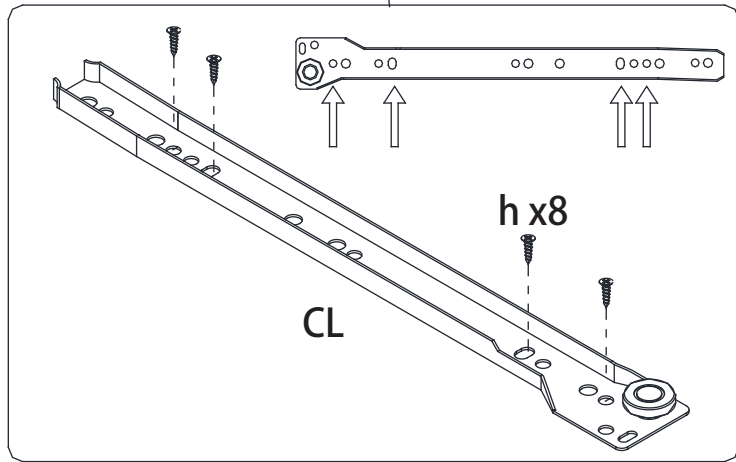
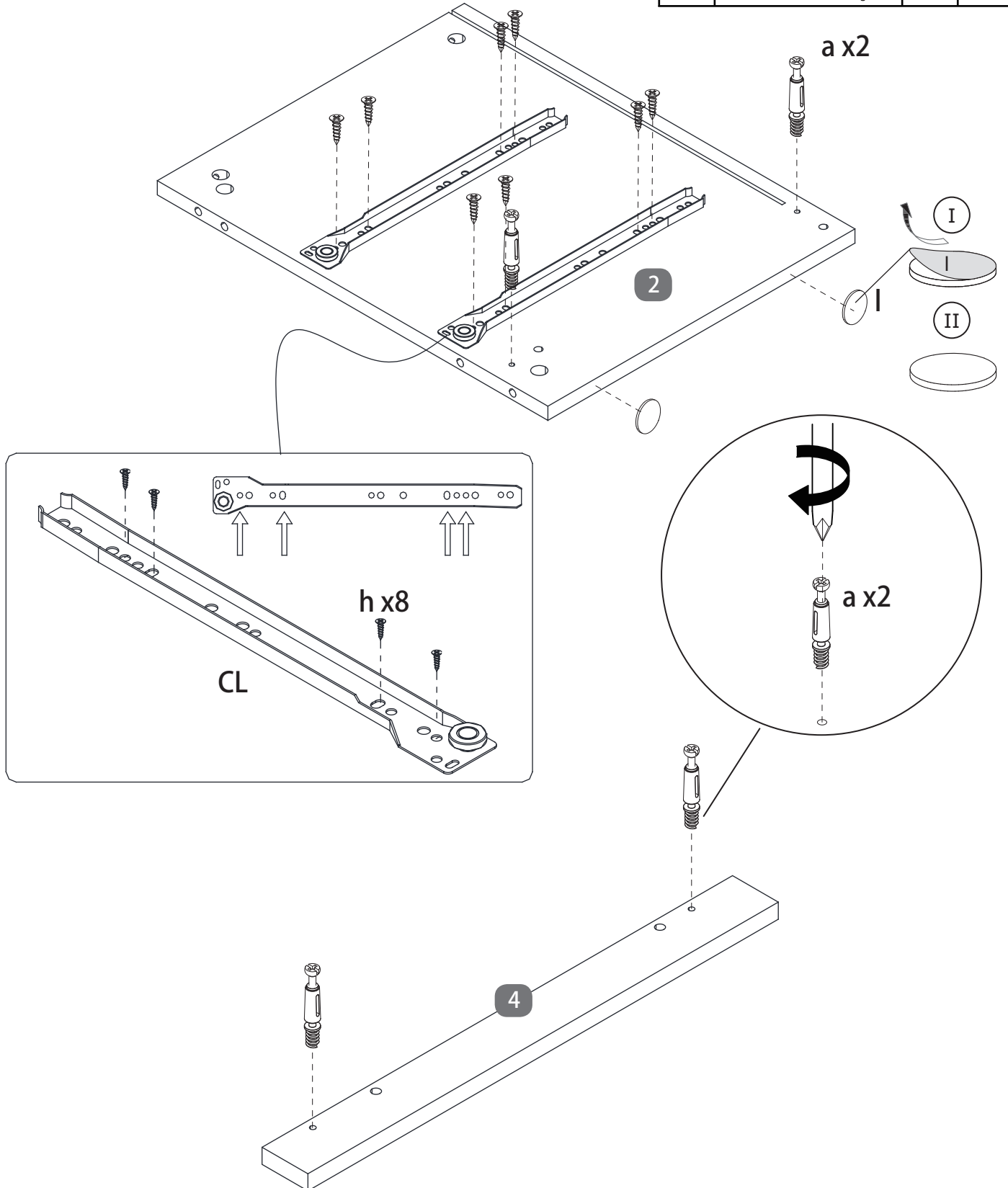

Stage
3

a		4	
h		8	
l		2	
CL		2	



Cabinet Assembly

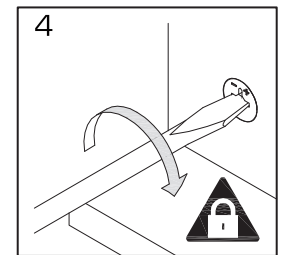
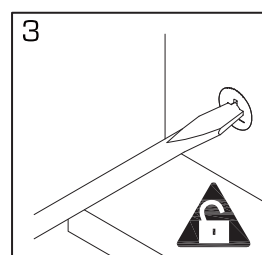
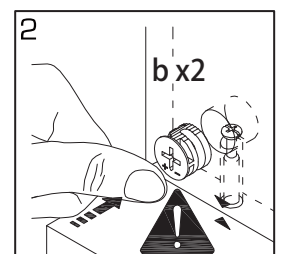
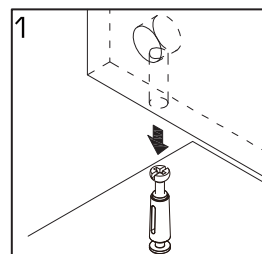
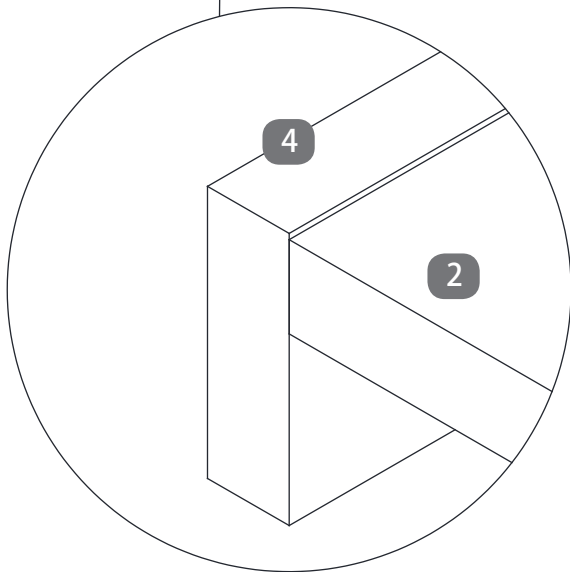
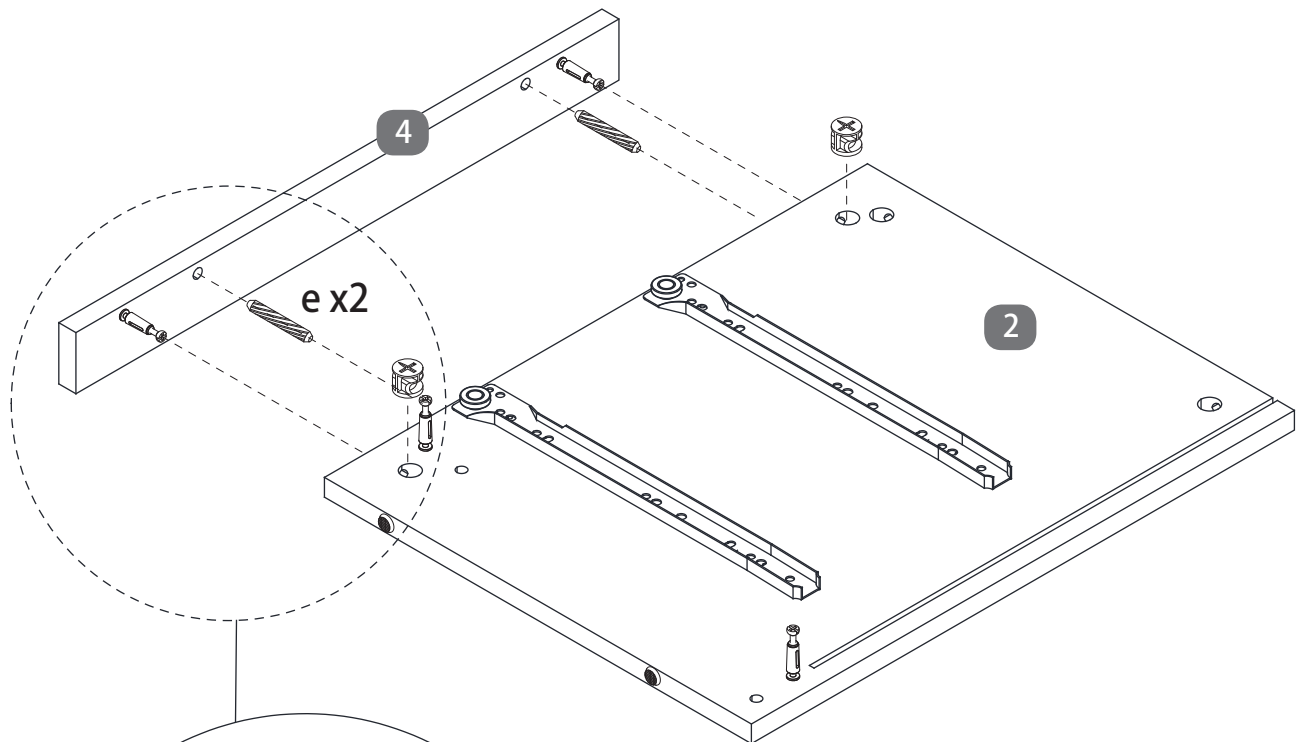

Stage
4

b		2	
e		2	



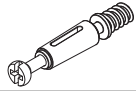

Cabinet Assembly

Stage
5

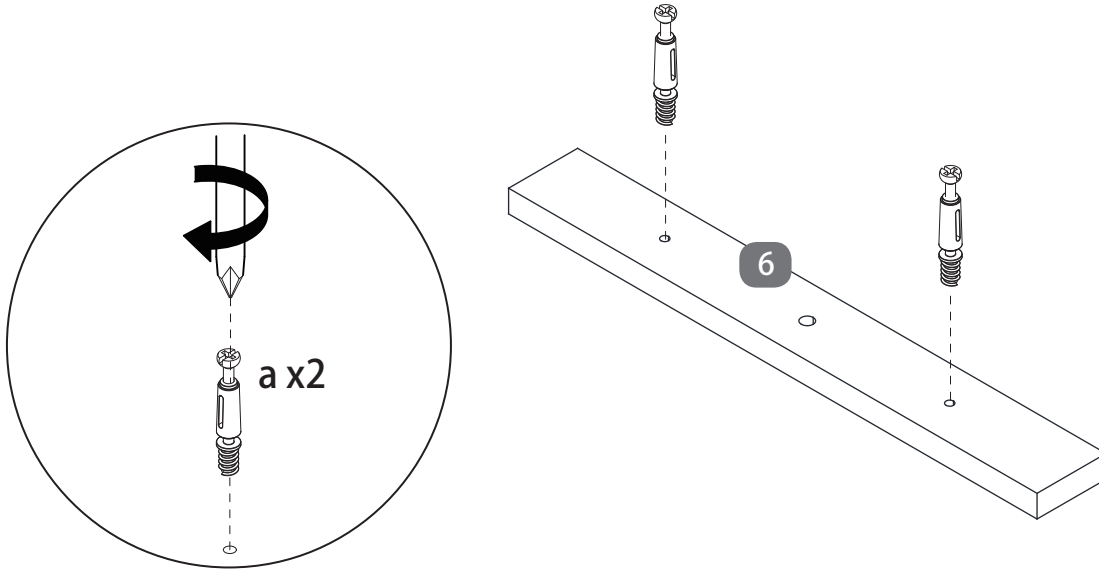
a		2	
---	---	---	---



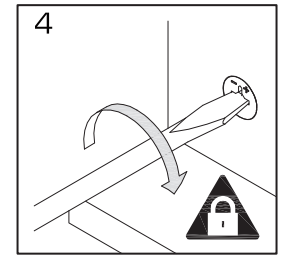
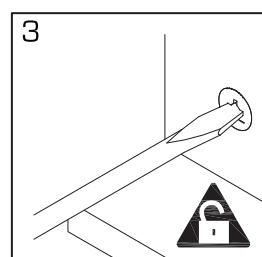
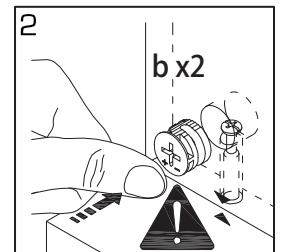
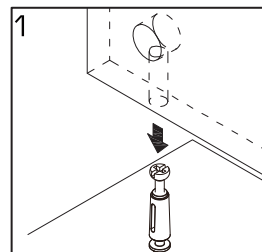
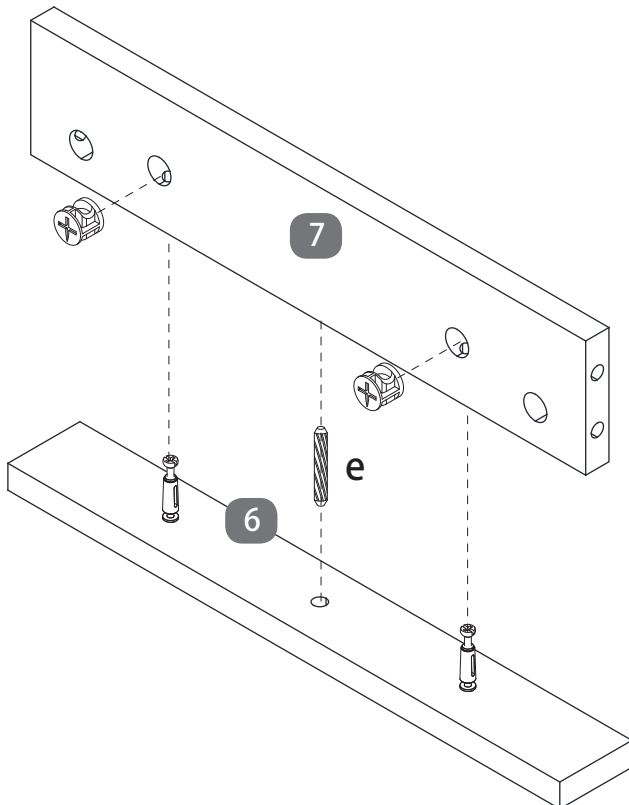

Stage
6

b		2	
e		1	



Cabinet Assembly

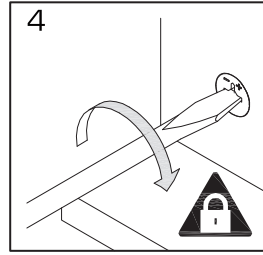
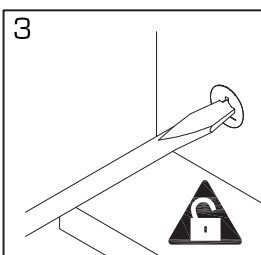
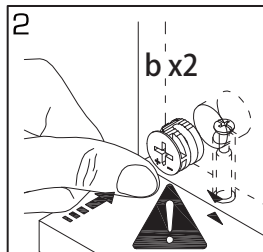
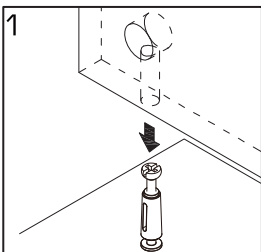
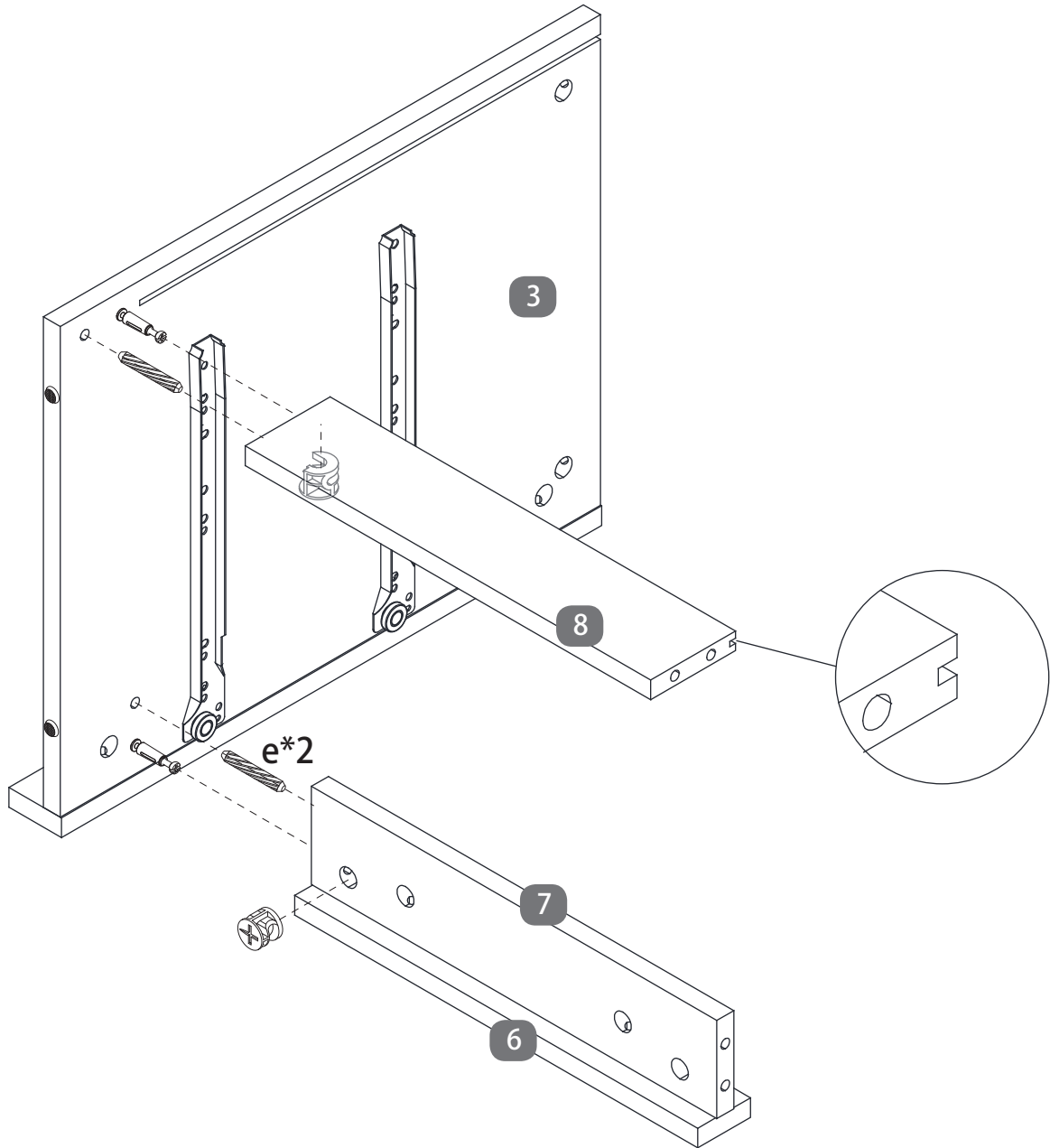

Stage
7

b		2	
e		2	



Cabinet Assembly

Stage
8

b		2	
e		2	

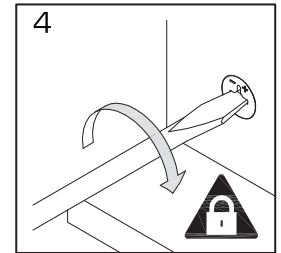
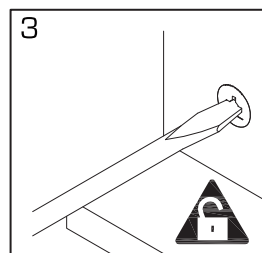
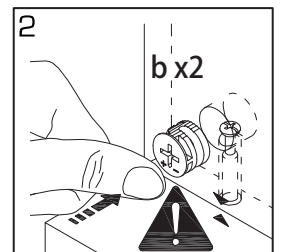
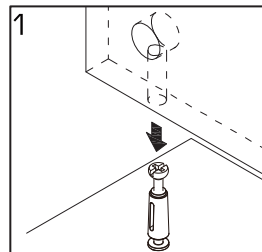
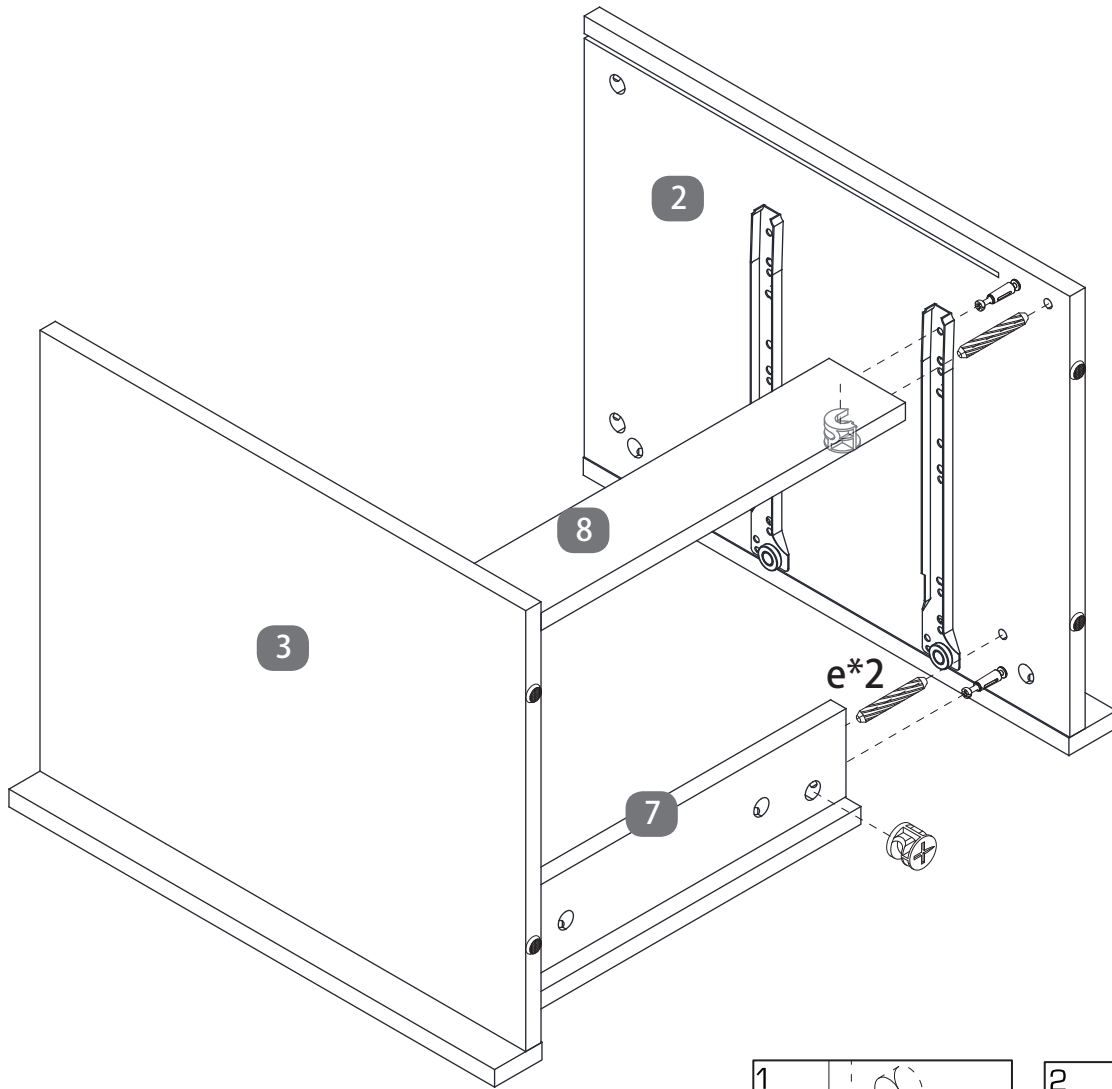

Cabinet Assembly



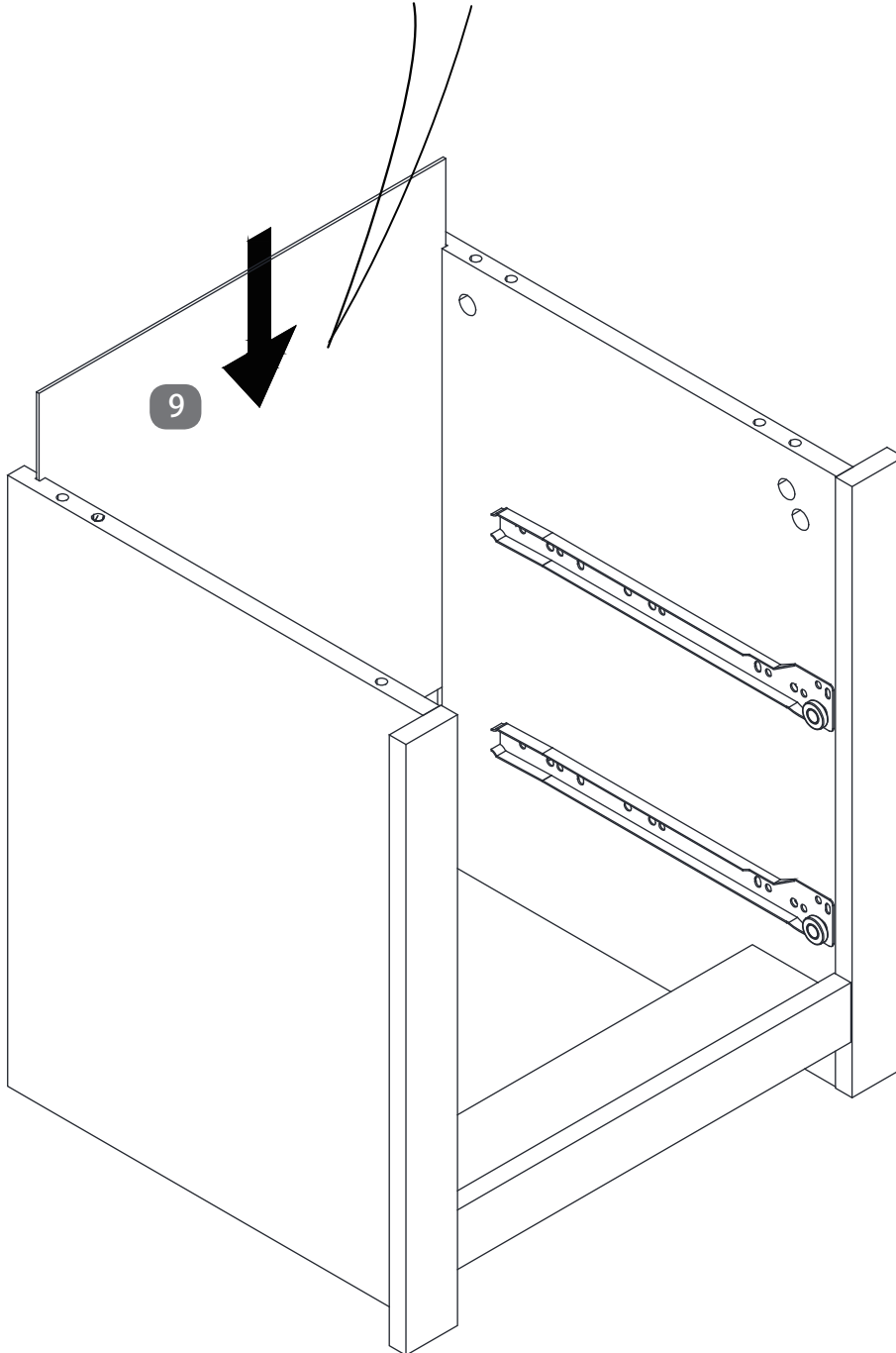

Stage
9

Fit the back panel (9) by sliding into the grooves. The coloured side should be on the outside of the cabinet and plain side on the inside.

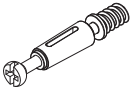

Cabinet Assembly

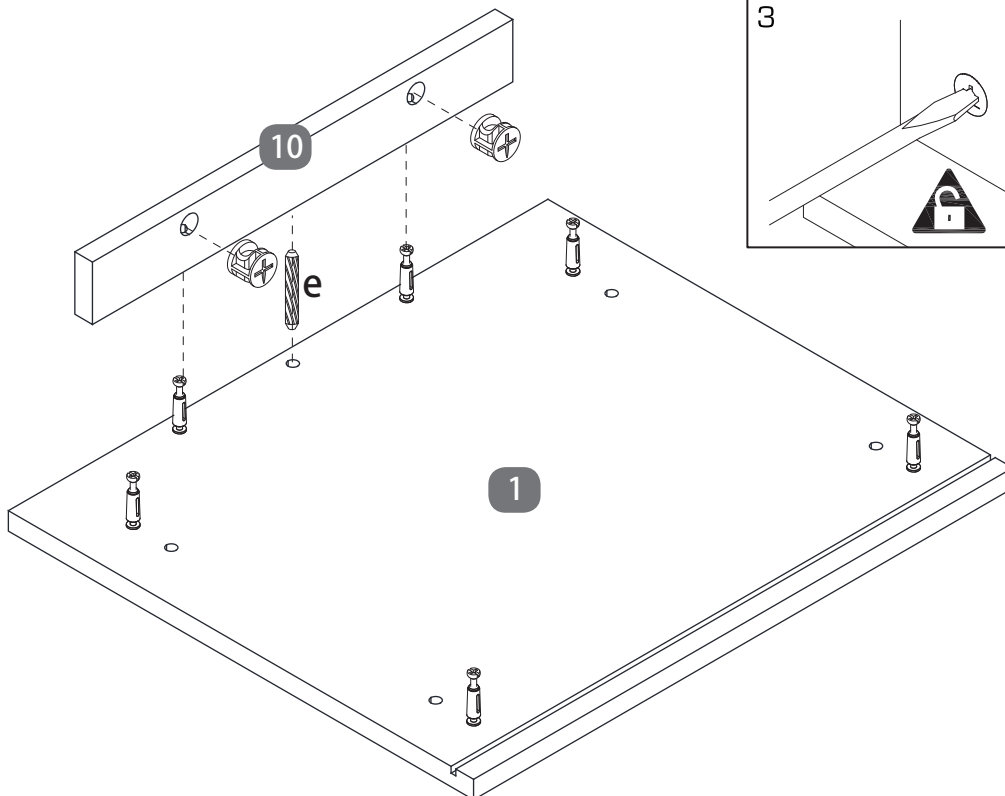
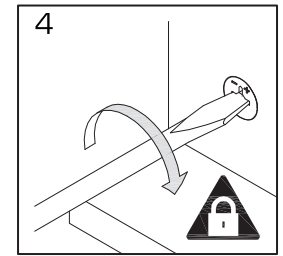
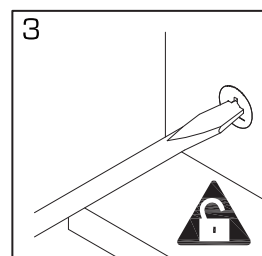
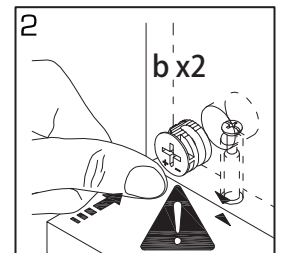
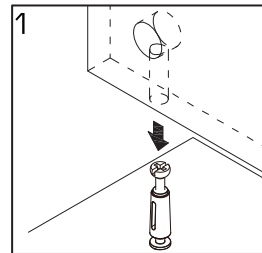
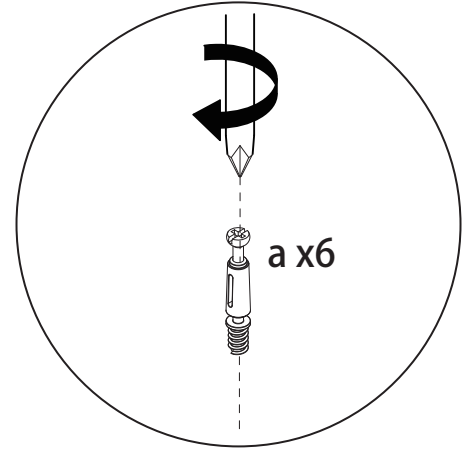
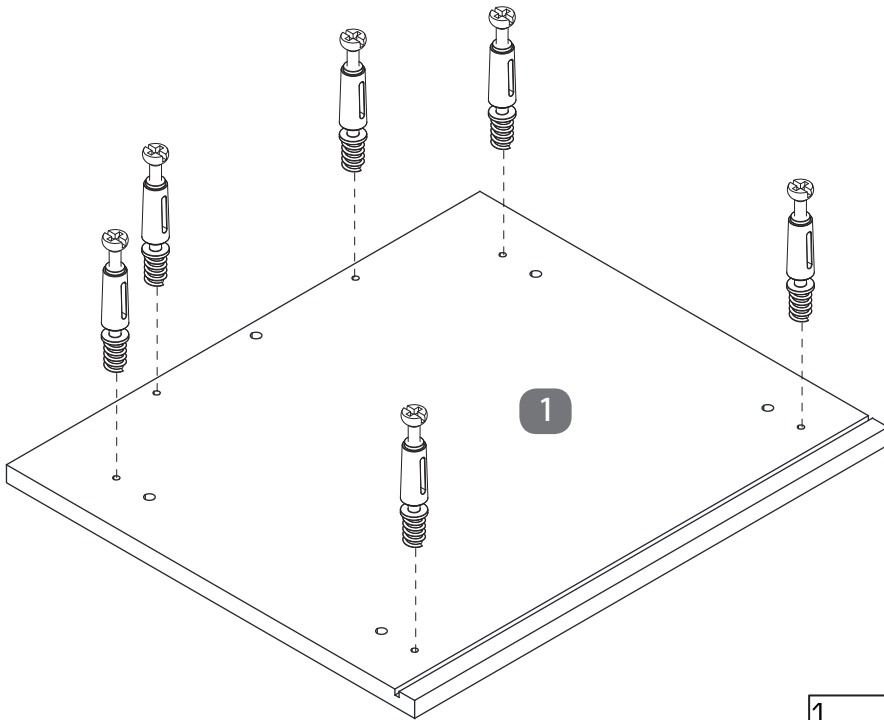

Stage
10

a		6	
b		2	
e		1	



Cabinet Assembly

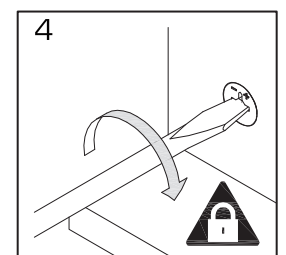
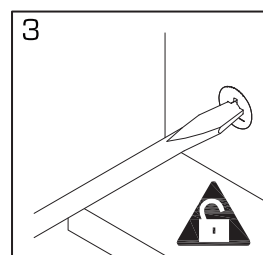
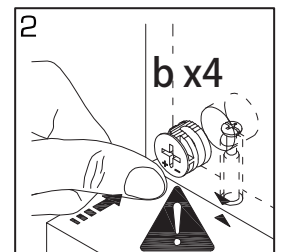
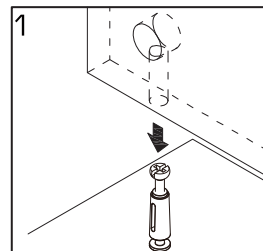
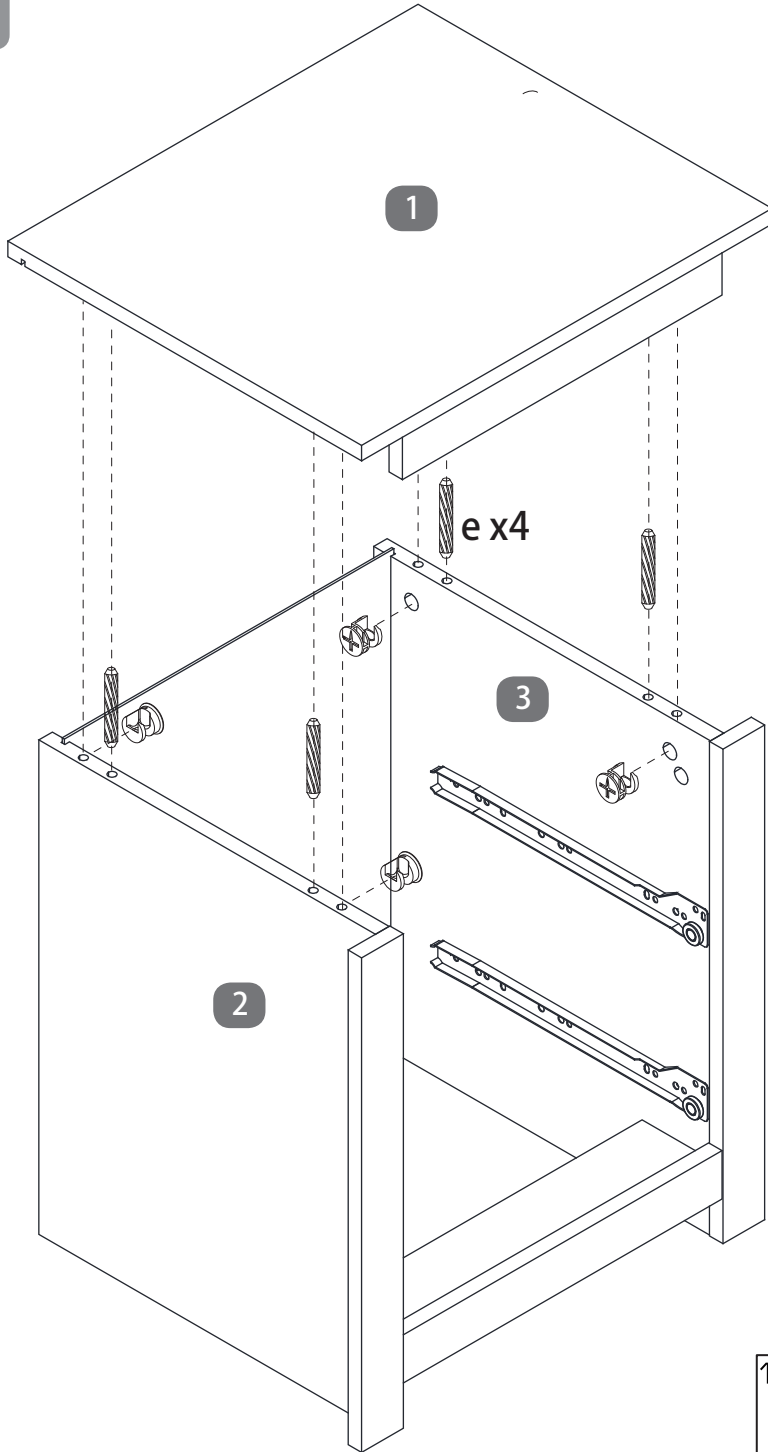

Stage
11

b		4	
e		4	



Cabinet Assembly

Stage
12

j		6	
k		6	

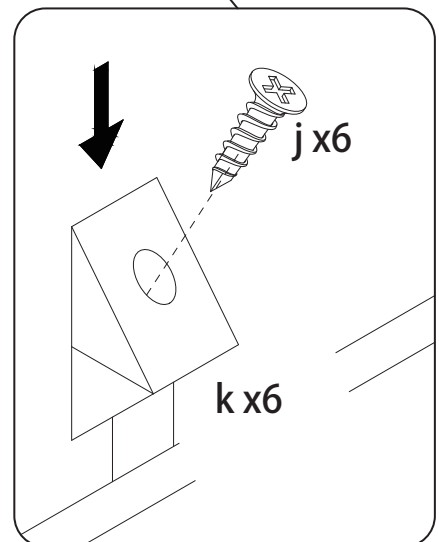
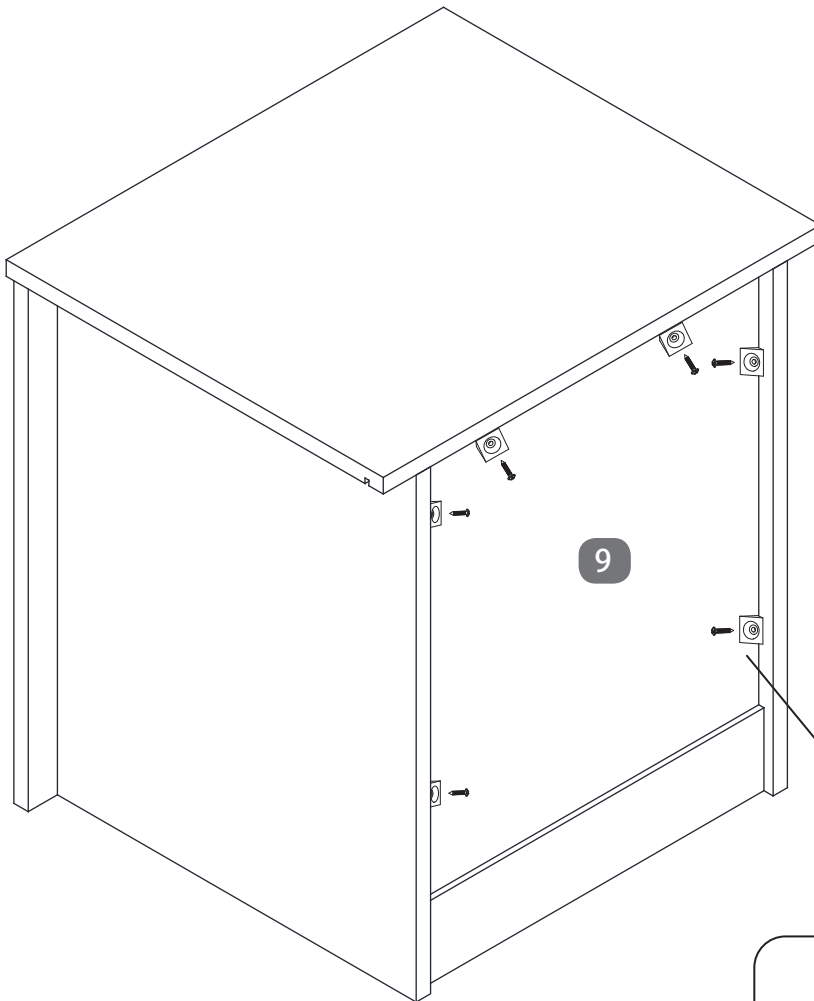

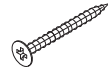

Stage 13

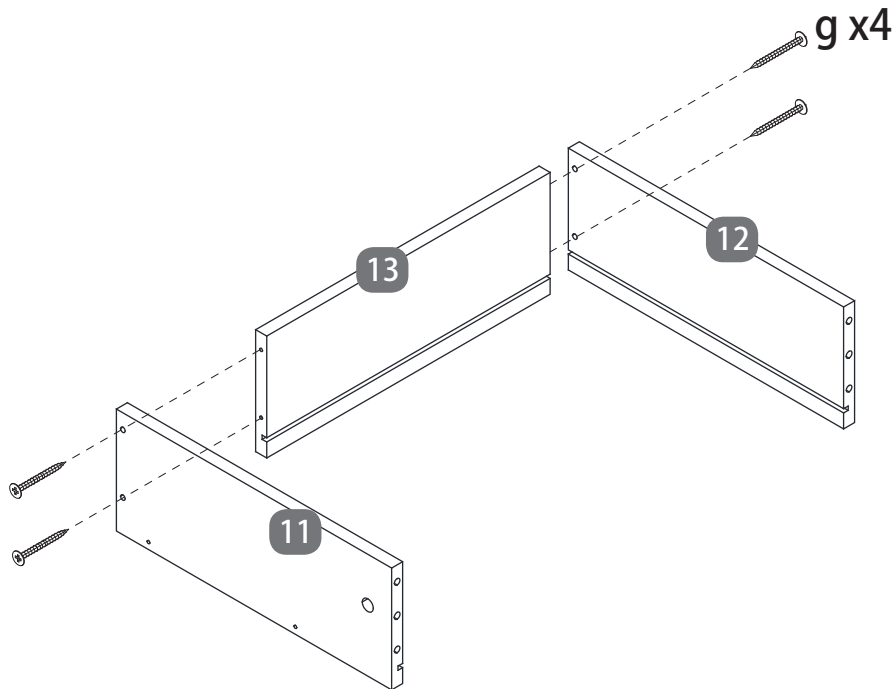

**Assemble
x2 Drawers**

Stage 14

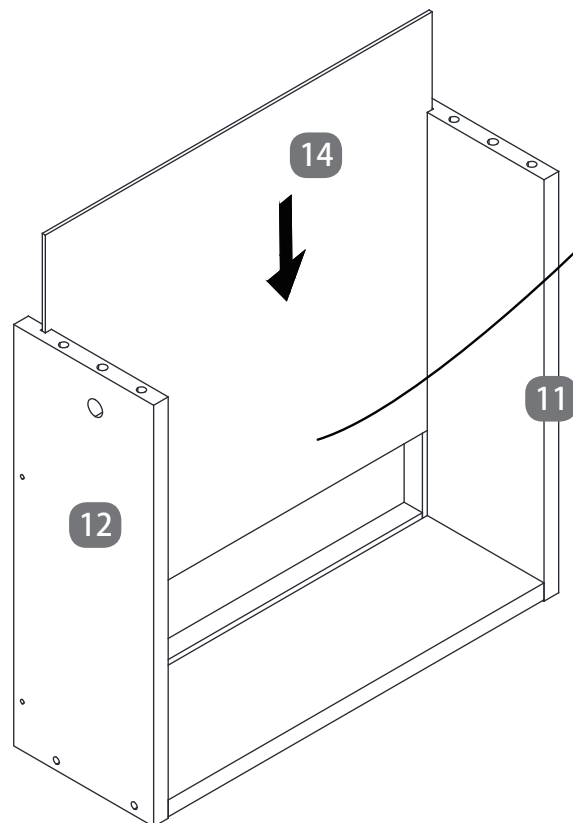



Drawer base panel (14). Place the coloured side on the inside of the drawer and the plain side underneath the drawer.

**Assemble
x2 Drawers**

Cabinet Assembly

Stage
15

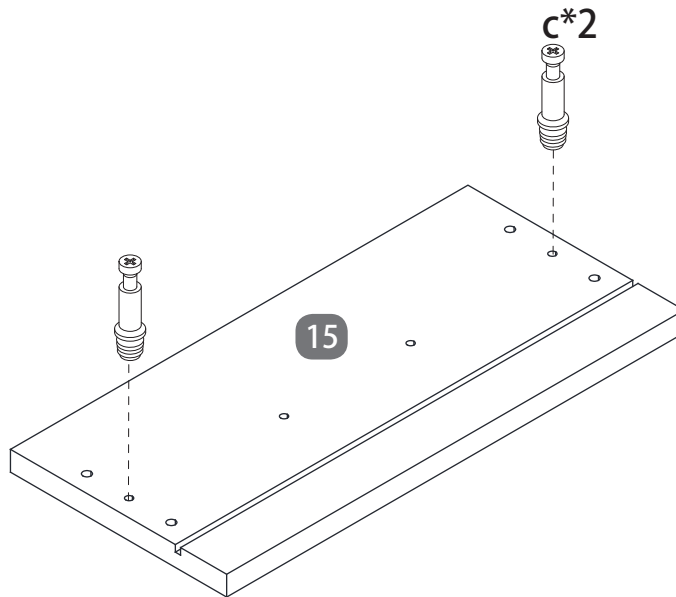

c		4	
---	---	---	---

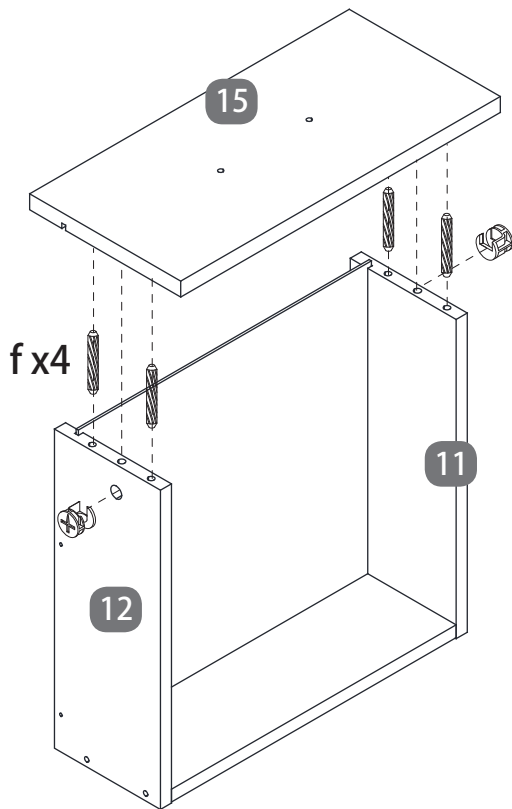

**Assemble
x2 Drawers**

Stage
16

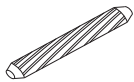

d		4	
f		8	

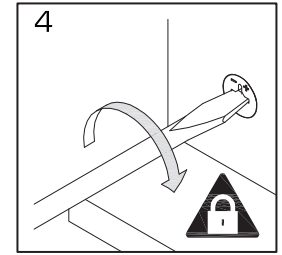
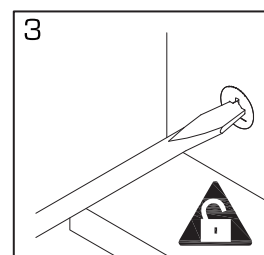
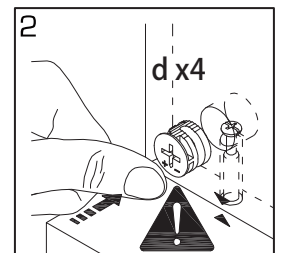
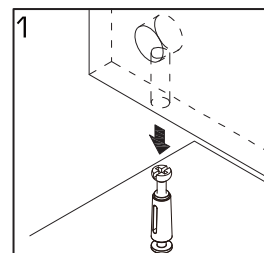

**Assemble
x2 Drawers**

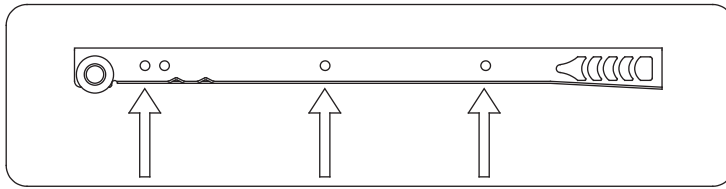

Cabinet Assembly

Stage
17



back
last hole

front
first hole

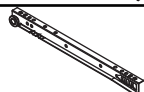

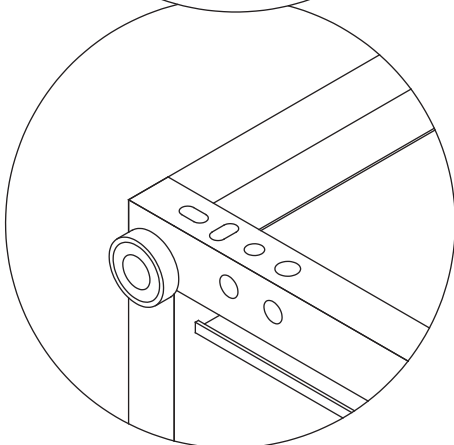
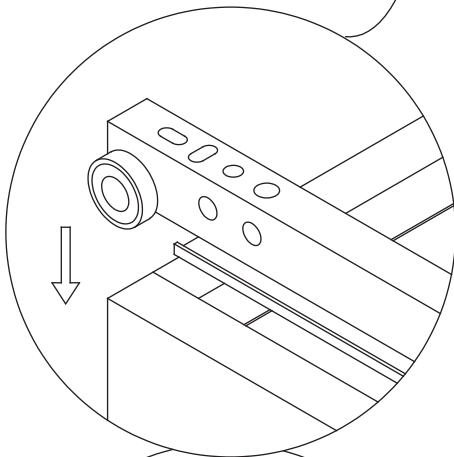
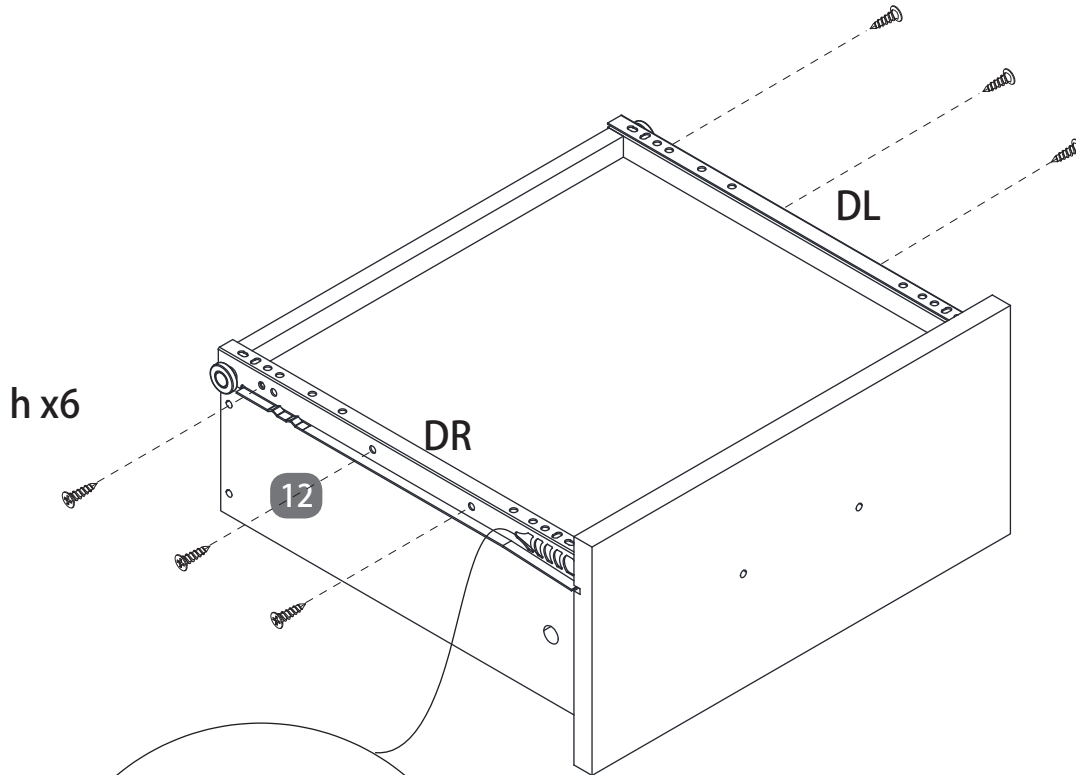
h		12	
DL		2	
DR		2	



**Assemble
x2 Drawers**

Cabinet Assembly

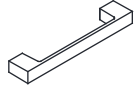
Stage
18

m		2	
n		4	

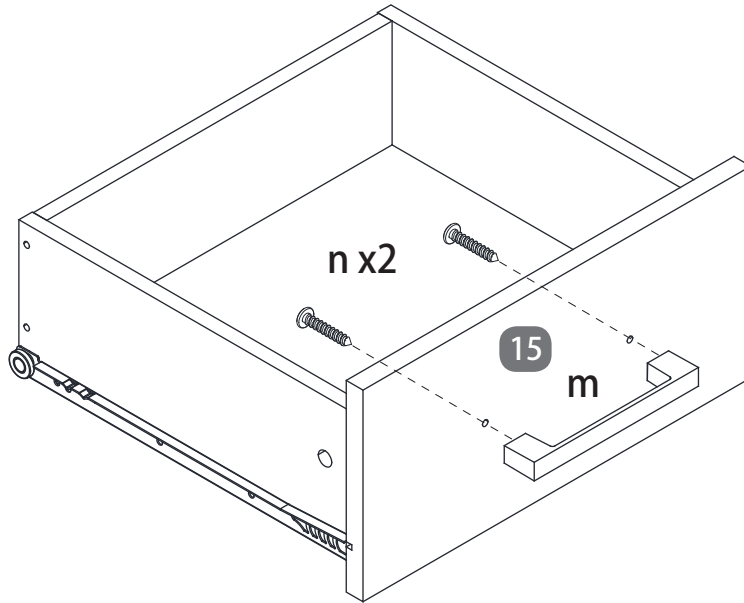

**Assemble
x2 Drawers**

Stage
19

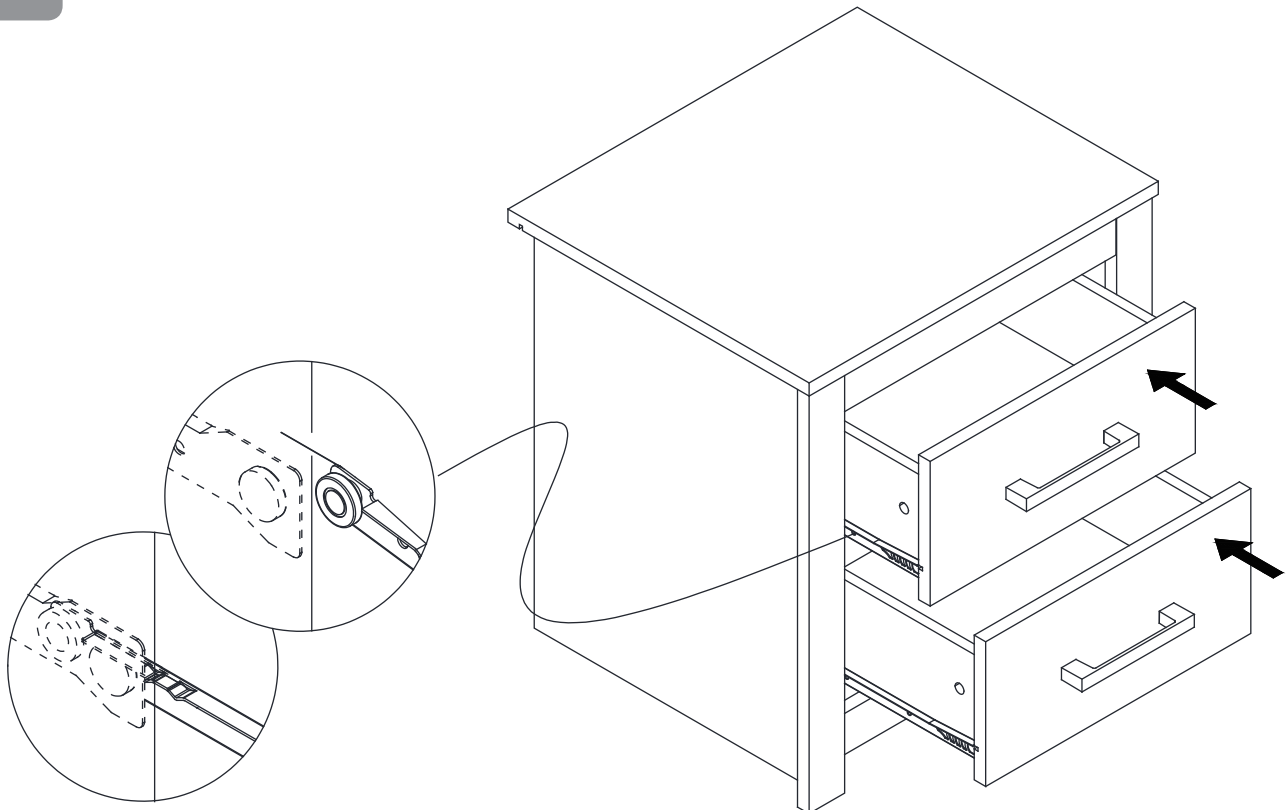

Cabinet Assembly

Stage
20

